

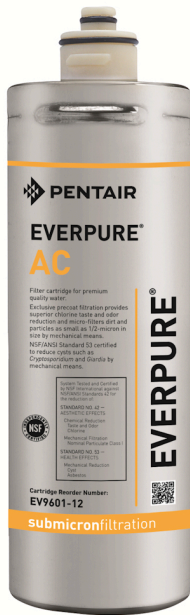

EV9601-12

AC Cartridge

Delivers premium quality water for vending and OCS applications



AC Replacement Cartridge:
EV9601-12

BENEFITS

Provides clear, fresh, premium quality ingredient water for great tasting drinking water and cold cup beverages

Everpure's unique filter blend using activated carbon reduces chlorine taste and odor and other offensive contaminants

Precoat submicron technology reduces dirt and particles as small as 1/2 micron in size

Reduces possible health contaminants such as asbestos fibers and Cryptosporidium and Giardia cysts

Does not remove fluoride

Sanitary cartridge replacement is simple, quick and clean. Internal filter parts are never exposed to handling or contamination

NSF Certified under NSF/ANSI Standards 42 and 53

INSTALLATION TIPS

- Never use saddle valve for connection
- Use 3/8" water line
- Install vertically with cartridge hanging down
- Allow 2-1/2" clearance below the cartridge for easy cartridge replacement
- Flush AC cartridge by running water through filter for three minutes at full flow

OPERATION TIPS

- Change cartridges on a regular 6 month preventative maintenance program
- Change cartridges when capacity is reached or when pressure falls below 10 psi
- Service flow rate must not exceed 0.5 gpm
- Always flush the filter cartridge at time of installation and cartridge change

APPLICATION/SIZING

- For cold cup vending machine and OCS applications
- Capacity: 750 gallons (2,835 L)

AC Cartridge

SPECIFICATIONS

Overall Dimensions:

10"H x 4"W x 4"D

Inlet connection:

3/8" FPT

Outlet connection:

3/8"

Service Flow Rate:

Maximum 0.5 gpm (1.9 Lpm)

Pressure Requirements:

10 psi - 125 psi (0.7 – 8.6 bar), non-shock

Maximum Temperature:

35°F - 100°F (2-38°C)

No electrical connection required

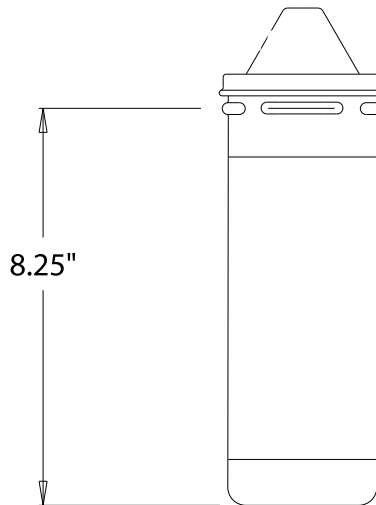

WARRANTY

Everpure water treatment systems (excluding replaceable elements) are covered by a limited warranty against defects in material and workmanship for a period of five years after date of purchase. Everpure replaceable elements (filter cartridges and water treatment cartridges) are covered by a limited warranty against defects in material and workmanship for a period of one year after date of purchase. See printed warranty for details. Everpure will provide a copy of the warranty upon request.



System Tested and Certified by NSF International against NSF/ANSI Standard 42 and 53 for the reduction of:

Standard No. 42: Aesthetic Effects
Chemical Unit
Taste and Odor Reduction
Chlorine Reduction
Mechanical Filtration Unit
Particulate Reduction, Class I:
99.9+% reduction of particles
one-half micron and larger in size
Standard No. 53: Health Effects
Mechanical Filtration Unit
Turbidity Reduction
Cyst Reduction
Asbestos Reduction

The contaminants or other substances removed or reduced by this drinking water system are not necessarily in your water. Do not use with water that is microbiologically unsafe or of unknown quality without adequate disinfection before or after the system. Systems certified for cyst reduction may be used with disinfected water that may contain filterable cysts.

Distributed by:

Andrew's
Water Treatment

Andrew's Water Treatment Ltd
47-49 Kensington Road,
Southport
PR9 0RY

Tel: 01704 531 556
<http://www.andrewswater.co.uk>
office@andrewswatertreatment.co.uk